

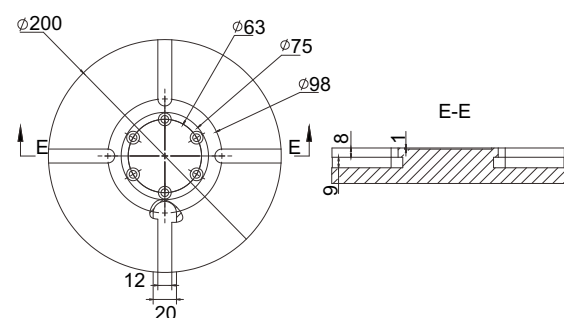

# TABLE



### CBS200



### CBS300

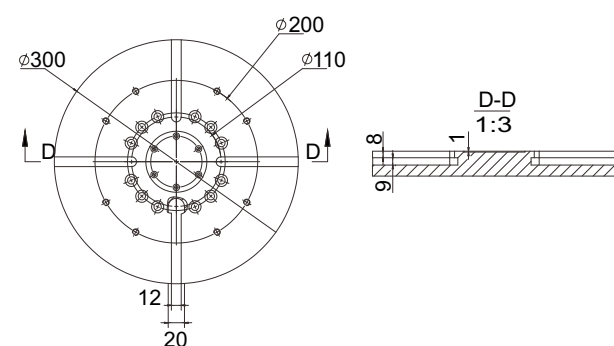

### CBS800

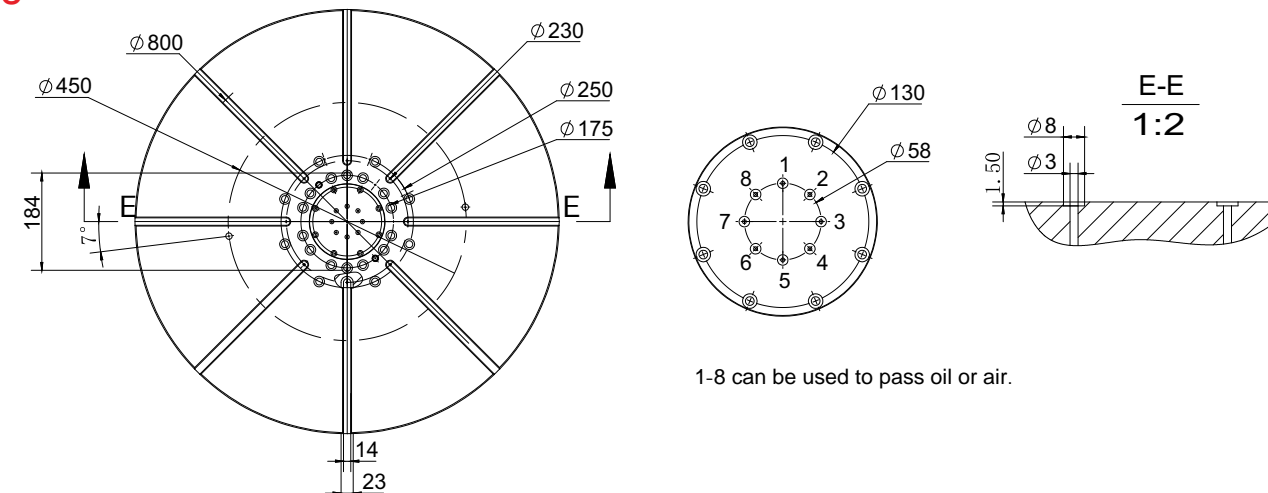

### CBS400

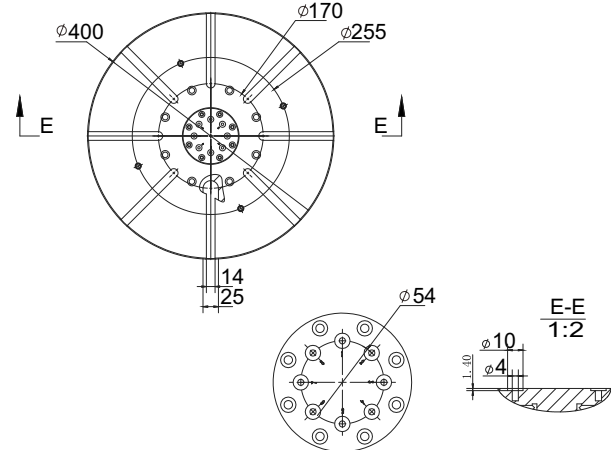

1 is for air tightness testing, 2 is for cylinder shrinkage.  
3-4, 5-8 and 7-8 are three sets of oil circuits

### CBS500

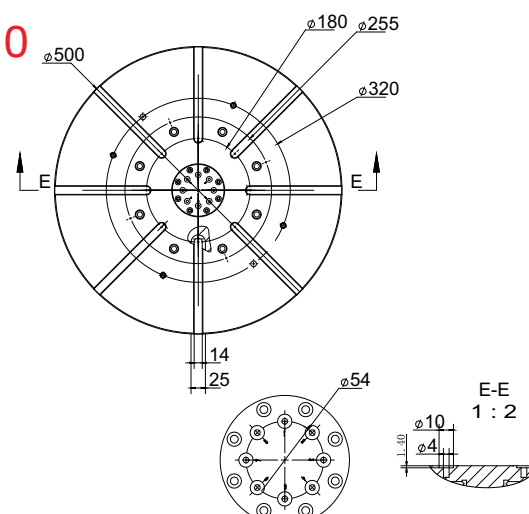

1 is for air tightness testing, 2 is for cylinder shrinkage.  
3-4, 5-8 and 7-8 are three sets of oil circuits

### CBS650(Option)

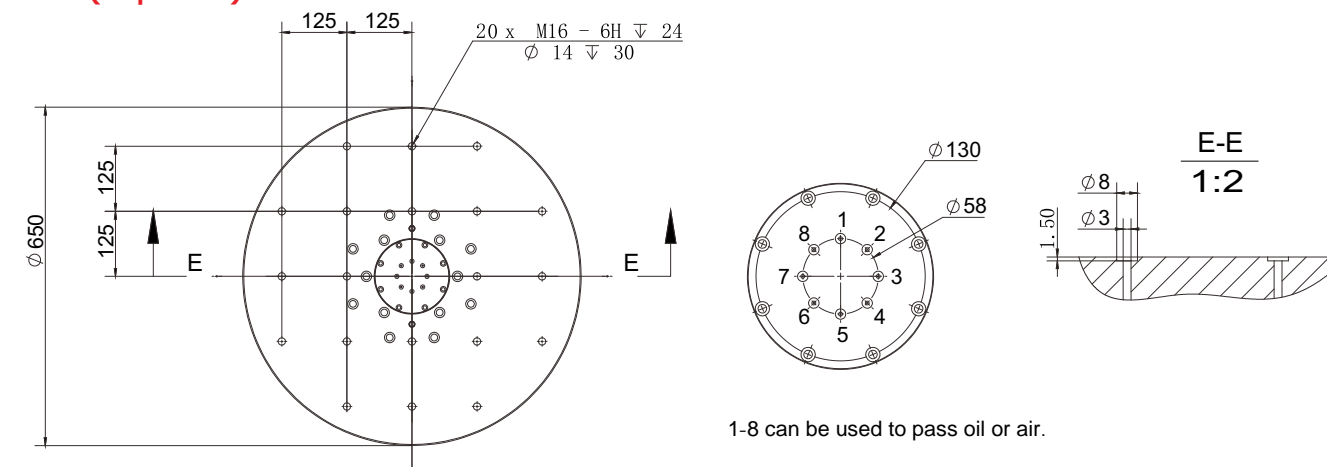

### CBS650

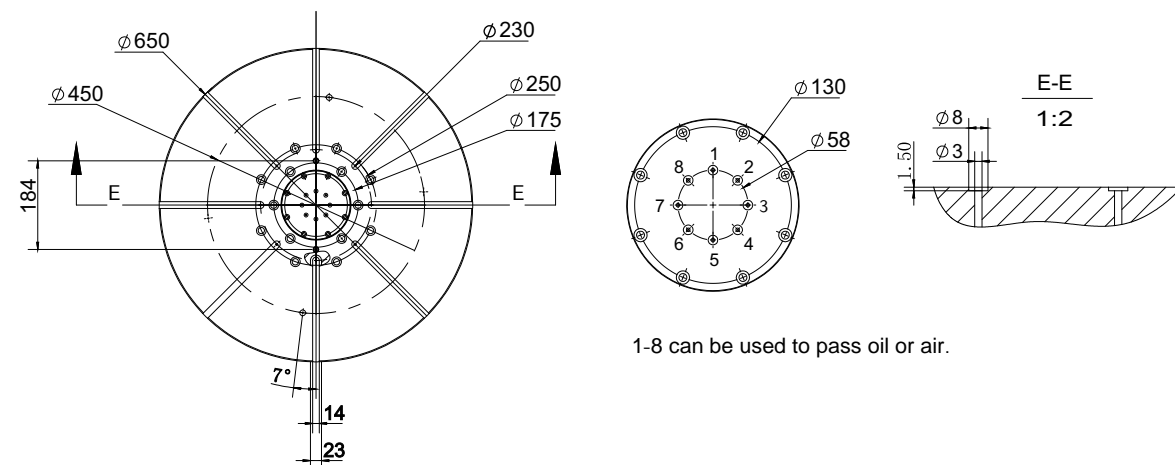

### CBS800(Option)

